

BANG BANG BANG

DESIGNED BY: RICH RICHARDS ,CA008

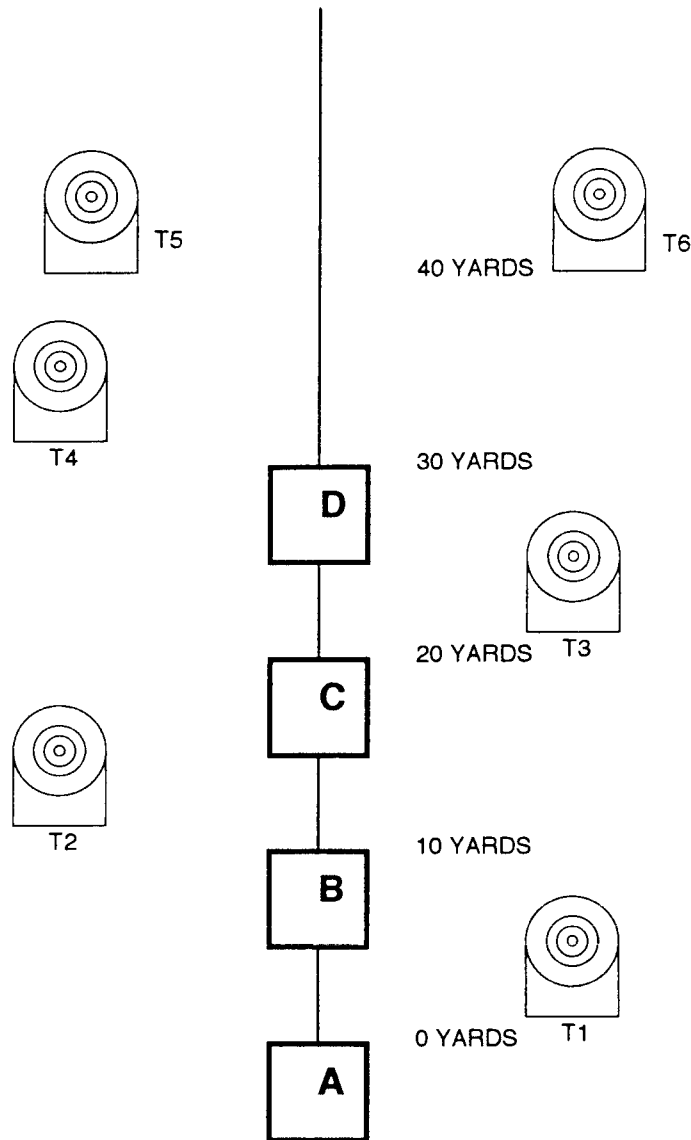

STAGE PROCEDURES:

STANDING IN SHOOTER BOX A HANDS RELAXED AT SIDE, ON SIGNAL DRAW AND ENGAGE T1, T5 AND T6 WITH TWO ROUNDS EACH. MOVE TO BOX B AND ENGAGE T2, T5, AND T6 WITH TWO ROUNDS EACH, MOVE TO BOX C AND ENGAGE T3, T5, AND T6 WITH TWO ROUNDS EACH, MOVE TO BOX D AND ENGAGE T4, T5, AND T6 WITH TWO ROUNDS EACH, FREESTYLE.

SCORING: TIME

TARGETS: 6 PAPER

MIN. ROUNDS 24

START SIGNAL: AUDIBLE

STOP SIGNAL: AUDIBLE

STARTING POSITION: STANDING IN SHOOTER BOX, HANDS RELAXED AT SIDES, FACING DOWN RANGE

PENALTIES:

PREMATURE START

+5 SEC

FOOT FAULTS

+5 SEC

EACH MISS

+5 SEC

EACH ON TARGET FOR WRONG SHOOTING BOX

+5 SEC

RANGE SET UP: T1 AND T3 ARE SET 3 YARDS DOWN RANGE FOR FRONT EDGE OF SHOOTING BOXES A AND C, AND 3 YARDS RIGHT OF CENTER LINE, T2 AND T4 ARE SET 3 YARDS DOWN RANGE FOR FRONT EDGE OF SHOOTER BOXES B AND D, AND 3 YARDS LEFT OF CENTER LINE, T5 AND T6 ARE SET 5 YARDS LEFT AND RIGHT OF CENTER LINE